

INSTRUCTION MANUAL Ver 1.1

High Speed Dome Camera





CAUTION

RISK OF ELECTRIC SHOCK
DO NOT OPEN



CAUTION : TO REDUCE THE RISK OF ELECTRICAL SHOCK, DO NOT OPEN THE COVERS.
NO USER SERVICEABLE PARTS INSIDE.
REFER SERVICING TO QUALIFIED SERVICE PERSONAL



This lightning flash with arrowhead symbol is intended to alert the user to the presence of un-insulated "dangerous voltage" within the product's enclosure that may be of sufficient magnitude to constitute a risk of electric shock to persons.



This exclamation point symbol is intended to alert the user to the presence of important operating and maintenance (servicing) instructions in the literature accompanying the appliance.



This Device complies with Part 15 of the FCC Rules. Operation is subject to the following two conditions:

- (1) This device may not cause harmful interface, and
- (2) This device must accept any interference received, including interference that may cause undesired operations.



Important Safety Guide

1. **Read, heed and follow all the Instructions**
Read all the safety and operating instructions before using the product.
2. **Keep this manual**
Keep this manual for reference in future.
3. **Attachments / Accessories**
Use only the attachments or accessories specified by the manufacturer.
4. **Installation**
 - Do not install near any heat resources such as radiators, heat registers, stoves, or other apparatus including amplifiers that produce heat. Improperly installed product may fall, cause serious injury to a child or adult and damage the product.
 - Do not block any ventilation holes or openings. Install in accordance with the manufacturer's instructions.
 - Use only with the cart, stand, tripod, bracket, mounting devices, or table specified by the manufacturer.
 - Installation should be done only by qualified personnel and conform to all the instructions by the manufacturer.
 - Refer all servicing to qualified service personnel.
 - Unless the product is specifically marked as IP67, more than IP67 or confirmed by the manufacturer, it is designed for indoor use only and it must not be installed where exposed to rain and moisture.
 - Do not load on the product.
 - Use stainless steel hardware to fasten the mount.
 - To prevent damage from water leakage when installing a mount outdoors on a roof or wall, apply sealant properly around holes.
 - These servicing instructions are for use by qualified service personnel only. To reduce the risk of electric shock, do not perform any servicing other than that contained in the operating instructions unless you are qualified to do so.
 - Use only replacement parts specified by the manufacturer.
5. **Power source**
This product should be operated only from the type of the power source indicated on the marking label.

 **Caution****❑ Operating**

- Before using, make sure that the power supply and others are properly installed.
- While operating, if any abnormal condition or malfunction is observed, stop using the product immediately and then contact your local dealer.

❑ Handling

- Do not disassemble or tamper with the parts inside the product.
- Do not drop or subject the product to shock and vibration as this can damage the product.
- Care must be taken when you clean the clear dome cover. Especially, scratch and dust will ruin the quality of the product.

❑ Installation and Storage

- Do not install the product in areas of extreme temperature, which exceed the allowable range.
- Avoid installing in humid or dusty places.
- Avoid installing in places where radiation is present.
- Avoid installing in places where there are strong magnetic fields and electric signals.
- Avoid installing in places where the product would be subject to strong vibrations.

TABLE OF CONTENTS

① Introduction	
Model Code	6
Features	8
Package Components	10
Main Part Description	11
② Installation	
DIP Switch Setup	12
Installation with Ceiling Mount Bracket	15
Installation with Wall Mount Bracket	16
Wiring and Cabling	17
③ Operation	
Check Point before Operation	20
Check Points for Preset and Pattern Function before Operation	20
OSD Menu	21
Reserved Preset (Hot Keys)	21
Preset	22
Swing	22
Pattern	23
Group	24
Other Functions	24
OSD Display	26
④ OSD Menu	
Quick Programming Guide	27
Main Menu	27
Display Setup	28
Privacy Zone Mask Setup	29
Camera Setup	31
Motion Setup	36
Preset Setup	39
Swing Setup	41
Pattern Setup	42
Group Setup	43
System Initialize	46
⑤ Specifications	47
Dimension	53

Model Code

E A O - N 3 7 T W - A I N

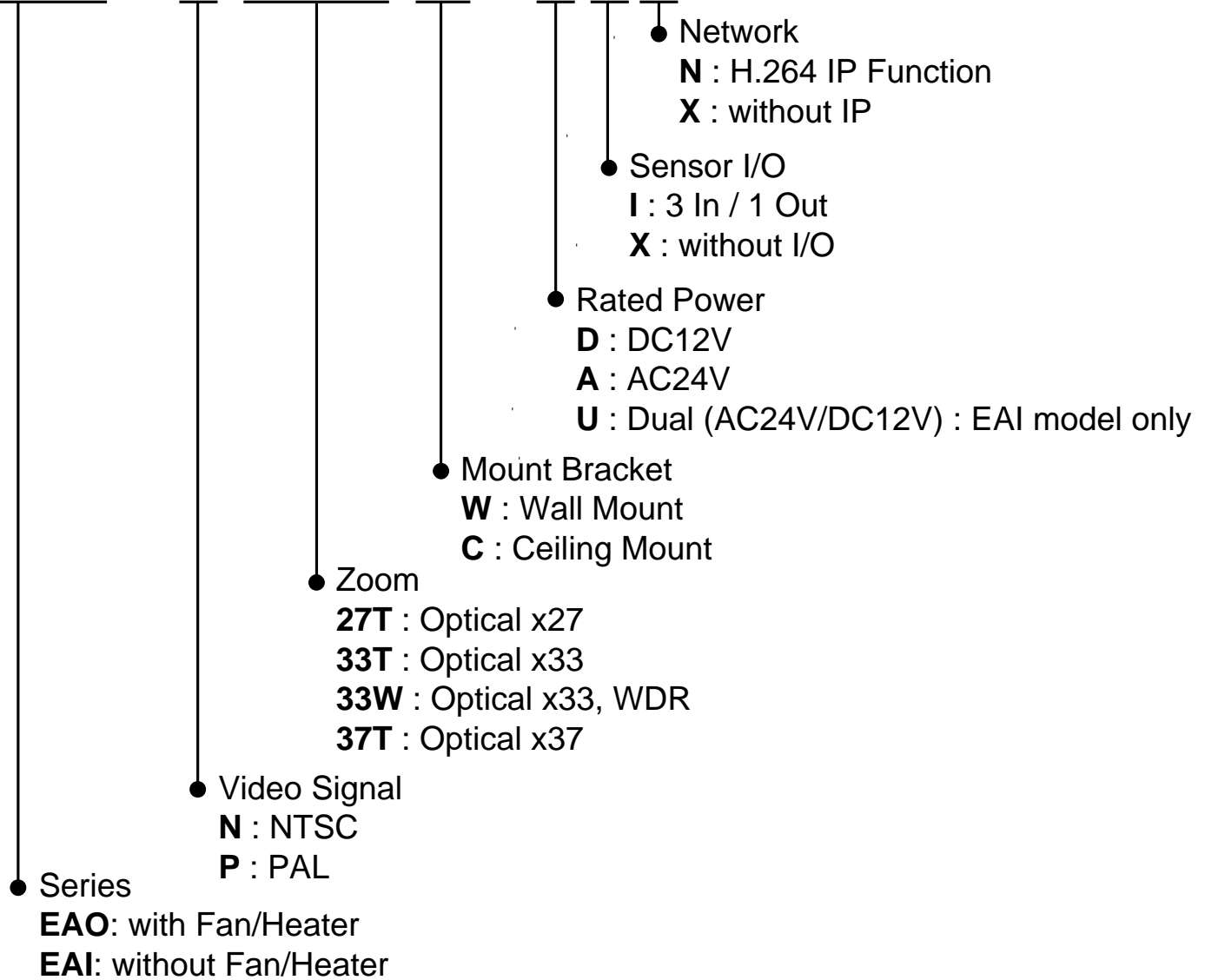

Features

□ Powerful Zoom Camera & Setup Options

- Image Sensor : 1/4" Double density interline transfer CCD (37T, 33W model)
1/4" Super HAD color CCD (27T, 33T model)
- Zoom : ×27 Optical Zoom, ×12 Digital Zoom (27T model)
×33 Optical Zoom, ×12 Digital Zoom (33T, 33W model)
×37 Optical Zoom, ×12 Digital Zoom (37T model)
- Day & Night, Privacy Mask, WDR and HLC (WDR : 37T, 33W models only)
- SNR (Super Noise Reduction) Function
- Various Focus Mode : Auto-Focus, Manual Focus, Semi-Auto Focus
- Various Setup Options in OSD Menu.

□ Powerful Pan/Tilt Functions

- MAX. 360°/sec High Speed Pan/Tilt Motion
- With the Vector Drive Technology, Pan/Tilt motions are accomplished along the shortest path. As a result, the time to target view is remarkably short and the video on the monitor is very natural in monitoring.
- With the Micro-Stepping Control Technology, the video looks very natural at high zoom magnification during a jog operation on a controller since the camera can be controlled by 0.05°/sec. Hence it is very easy to make the camera focus on desired target views at high zoom magnification. Additionally it is easy to make the camera focus on desired positions with zoom-proportional pan/tilt movement.

□ Preset, Pattern, Swing, Group, Privacy Mask and More...

- MAX. 127 Presets are programmable and each preset can have its own parameter values independently from the other presets.

For an example, refer to the below table.

Preset No.	White Balance	Auto Exposure	...	Label	Remarks
Preset 1	Case A	Case 3		"ENTRANCE"	
Preset 2	Case C	Case 5		"WAREHOUSE"	
Preset 3	Case V	Case 2		"OFFICE"	
...					
Preset 95	—	—	—	—	Reserved for OSD Menu
...					
Preset 128	Case K	Case 9		"TERRACE"	

- MAX. 8 sets of Swing are programmable. This function is that the camera moves repetitively between two preset positions at programmed speeds.
- MAX. 4 Patterns are programmable. This function is that the camera memorizes the path (mostly curve path) by the joystick of the controller and revives the trajectory operated by the joystick as closely as possible.
- MAX. 8 sets of Group are programmable. This function is that the camera memorizes the combination of Presets, Pattern and/or Swings sequentially and runs Presets, Pattern and/or Swings repetitively. A Group can be combined up to 20 functions with any of Preset/Pattern/Swing.
- MAX. 8 Privacy Masks are programmable, not to intrude on any other's privacy.

❑ **PTZ(Pan/Tilt/Zoom) Control**

- With the RS-485 communication connection, MAX. 255 units of cameras can be connected to a single controller.
- Pelco-D or Pelco-P protocols can be selected as a control protocol in the current firmware version.

❑ **OSD(On Screen Display) Menu**

- OSD menu is provided to display the status of camera and to configure the functions interactively.
- The information such as Camera ID, Pan/Tilt Angle, Direction, Alarm Input and Preset is displayed on screen.

❑ **Alarm In/Out Function(Only for the models which have I/O function)**

- 3 alarm sensor inputs and 1 alarm sensor outputs are available.
- Alarm sensor input is decoupled with photo-couplers to avoid external electric noise and shock perfectly.
- Both of N.O.(Normal Open) sensors and N.C.(Normal Close) sensors can be used and the signal range of the sensor input is from DC 5.0V to 12.0V for various applications.
- The camera can be set to move to a Preset position or to run functions such as Pattern, Swing and Group when there are external sensor activations. Also "Post Alarm" function is possible, which is supposed to activate after user-defined time period and sequentially in succession to the action by external sensor activations.

❑ **Reserved Presets(Hot Keys)**

- Most camera setup options can be set up easily and directly with the reserved presets (Hot Keys), without entering into OSD menu. For more information, refer to "Reserved Presets(Hot Keys)" in this manual.

❑ Network Function(Only for the IP addressable models)

- Network functions including remote monitoring, bidirectional audio and others are available through IP based network such as LAN, ADSL/VDSL, and Wireless LAN. For more information, refer to the separated manual for IP Addressable models.

❑ Perfect Outdoor Environment Compatibility and Easy Installation

- The fans and heaters are built-in in the camera for cold and hot temperature environment. Also idealistic mechanical design protects the camera from water and dust. (IP67 when installed properly with wall mount bracket only / Only for outdoor models)
- It is easy to install and repair the camera.

Package Component

□ Product & Accessories

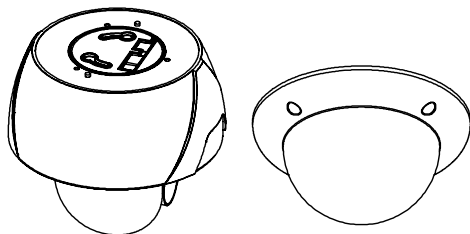

● Main Body & Surface Mount Bracket

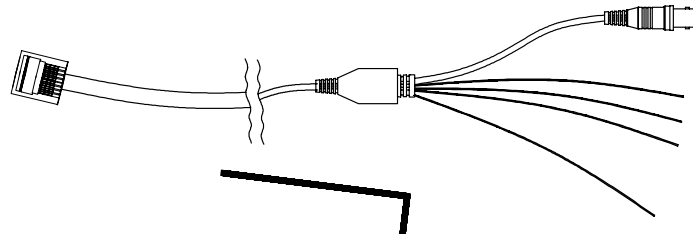

● Default Accessories
[Main Cable, Wrench]

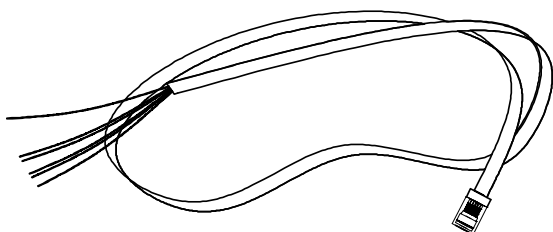

● Accessories for The Models with Alarm In/Out Function
[I/O Cable]

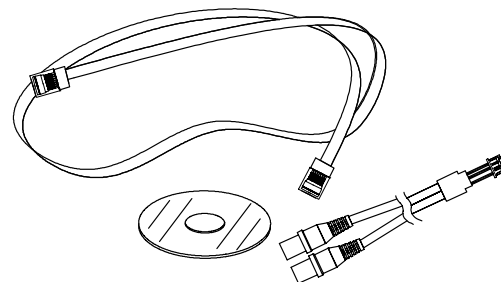

● Accessories for The IP Addressable Models
[Crossover LAN Cable, Audio Cable, CD]

□ Brackets (Optional)

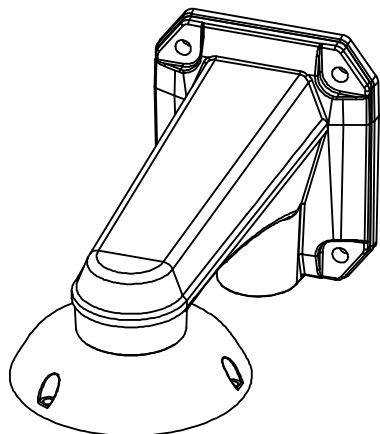

● Wall Mount Bracket
[Screws : Machine M5×15, Hex Lag #14×50]

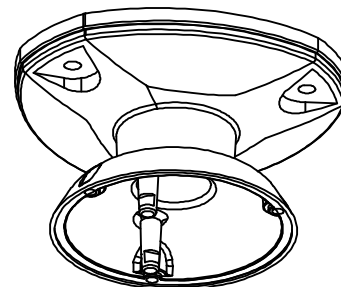

● Ceiling Mount Bracket
[Screws : Machine M5×15, Anchor Bolt 3/8"×70]

Main Part Description

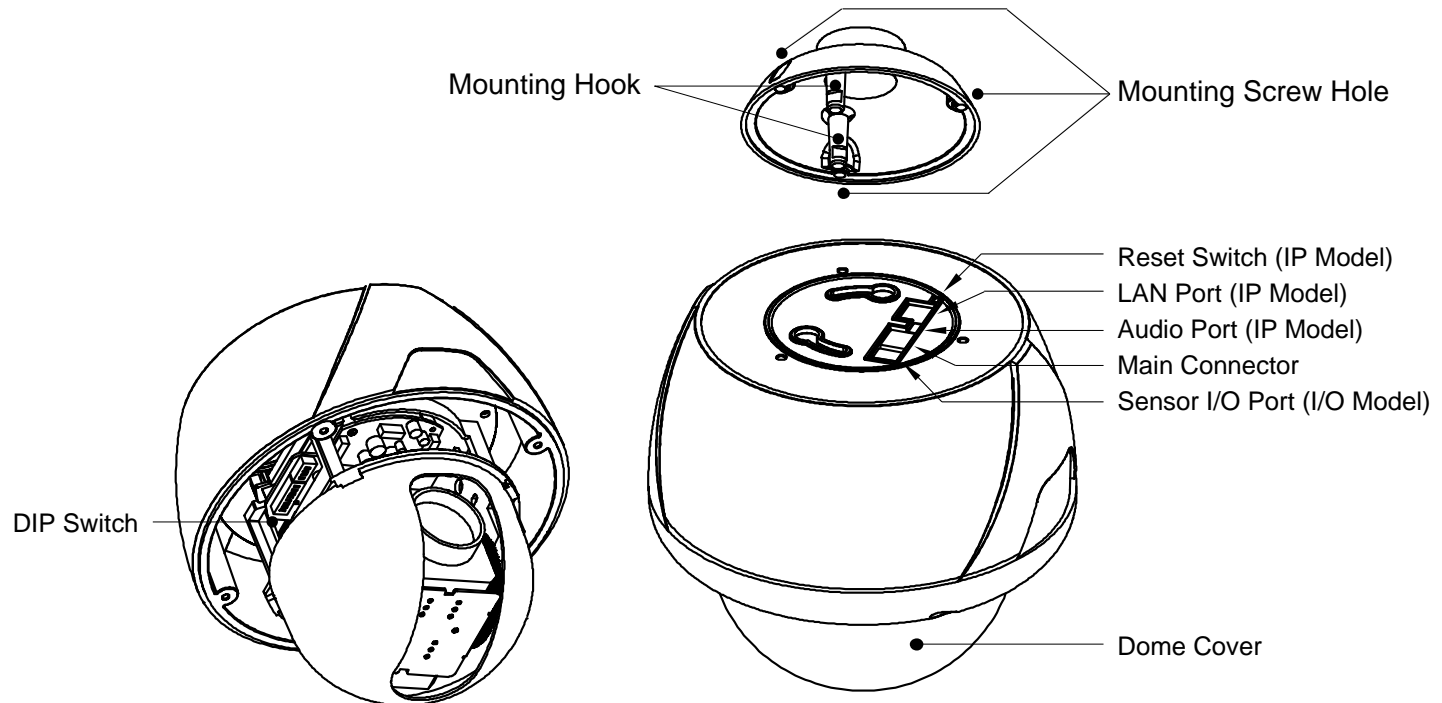

- **Dome Cover** Do not detach the protection vinyl from the dome cover before finishing all the installation process to protect the dome cover from scratches or dust.
- **DIP Switch** Used to set up camera IDs and protocols.
- **Mounting Hook** Used to assemble the main body with wall mount bracket or ceiling mount bracket. Insert the mounting hooks into the holes on the surface of the main body and turn the main body.
- **Mounting Screw Hole** Used to assemble the main body with a bracket with screws.
- **Main Connector** Used for the power wire, the video cable and the RS-485 communication cable connection.
- **Sensor I/O Port** Used for the sensor in/out connection. (The sensor I/O function possible models only)
- **LAN Port** Used for the Ethernet connection. (IP addressable models only)
- **Audio Port** Used for the audio in/out connection. (IP addressable models only)
- **Reset Switch** Used to initialize all the network configurations to the factory default. (IP addressable models only) Press the button for more than 5 seconds to initialize the network system.

DIP Switch Setup

Before installing the camera, set up the DIP switch to configure the camera ID and the communication protocol.

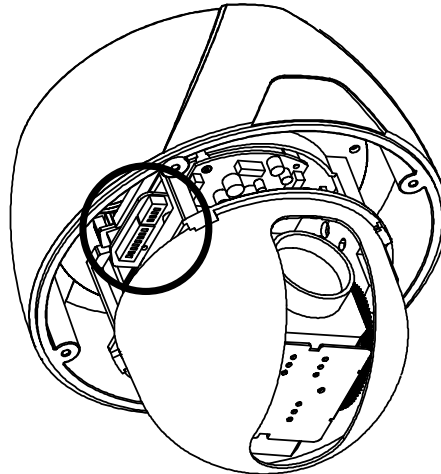

□ Camera ID Setup



- ID numbers of cameras are set up with binary numbers. See the examples shown below.

Pin	1	2	3	4	5	6	7	8
Binary Value	1	2	4	8	16	32	64	128
ex) ID=5	on	off	on	off	off	off	off	off
ex) ID=10	off	on	off	on	off	off	off	off

- The camera ID range is “1~255”. **Camera ID must not be “0”!**
- The factory default of the camera ID is “1”.
- Match the camera ID with the Cam ID setting of your DVR or Controller to control the camera.
- If you are connecting a single camera to a controller, terminate the camera. When connecting more than one camera to a single controller, terminate the last camera on the communication line. The last camera means the camera farthest in cable length from the controller.
- Note that the total length of the communication cable between a controller and the camera(s) on the same communication line must be less than 1.2Km.

□ Communication Protocol Setup

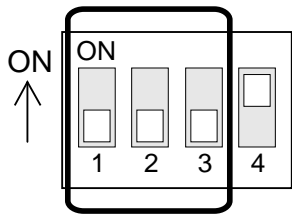

- Select an appropriate Protocol with the DIP switch combination.

Switch Mode			Protocol
P0 (Pin 1)	P1 (Pin 2)	P2 (Pin 3)	
OFF	OFF	OFF	PELCO-D, 2400 bps
ON	OFF	OFF	PELCO-D, 9600 bps
OFF	ON	OFF	PELCO-P, 4800 bps
ON	ON	OFF	PELCO-P, 9600 bps
Others			Reserved

- Match the camera protocol with the camera protocol in the setting of your DVR or controller to control the camera.
- Adjust the DIP switch after turning off the camera. If you changed the camera protocol by changing the DIP S/W, the change will be effective after you reboot the camera.
- The factory default protocol is “Pelco-D, 2400 bps”.

□ Terminal Resistor Setup

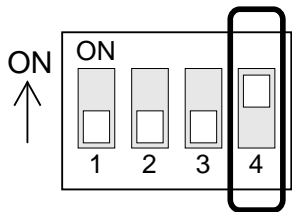

The terminal resistor is used for the following cases.

- **Case 1 : In case that the control cable length between a camera and a controller is relatively very long (1:1 Connection)**

If the communication cable length is very long, the electrical signal will bound in the terminal point. This reflected signal causes distortion of original signal. Accordingly, the camera can be out of control. In this case, the terminal resistor of both sides i.e. the camera and the controller must be set to 'ON' state.

- **Case 2 : In case that multiple cameras are connected to a controller.**

Due to similar reasons with the case 1, the terminal resistor of the controller and the last camera must be set to 'ON' state. The last camera means the camera farthest in cable length from the controller. Do not turn on the terminal resistor of all the cameras on the same communication cable.

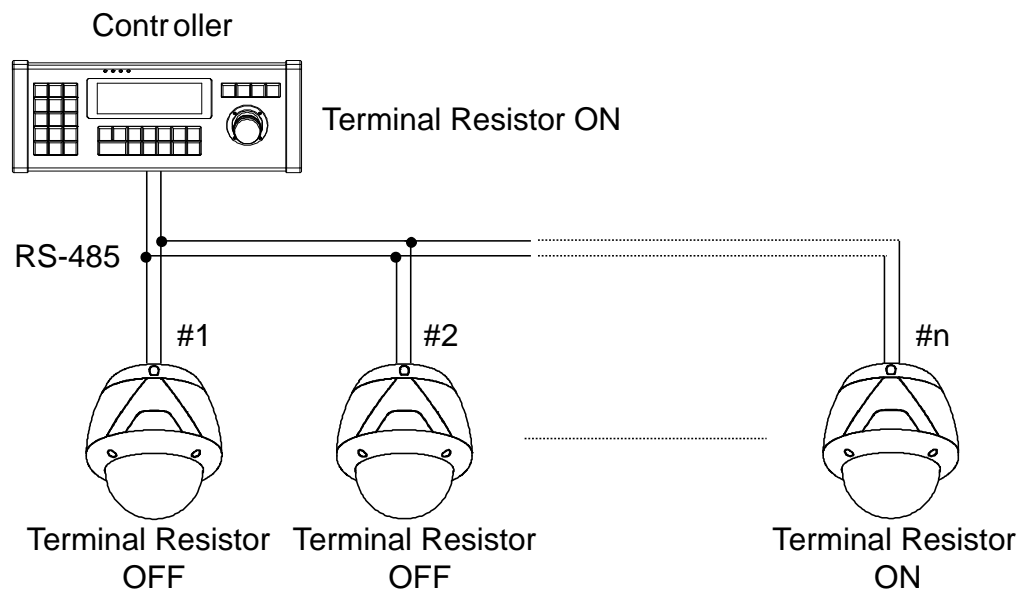

Installation with Ceiling Mount Bracket

- ① Remove the ceiling tile from the ceiling and cut a hole whose diameter is 30~40mm on the ceiling tile to pass the wire(s) and cable(s) through to the upside of the ceiling. (In case of the wiring and cabling through the mounting surface only) Then prepare the ceiling mount bracket. Pull the wire(s) for the system as below. (Anchor Bolt 3/8"×70)
- ② Pull the wire(s) and cable(s) for the system as below. Wire the cable(s) to the ports. Insert the mounting hooks into the holes on the surface of the main body and turn the main body. Assemble the main both with the camera mount adaptor with the 3 screws. (Machine M5×15)

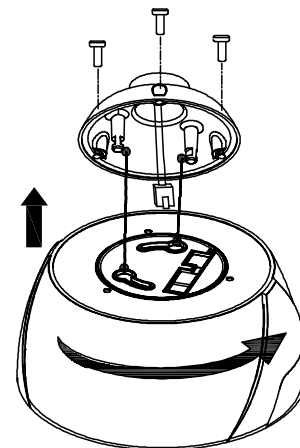
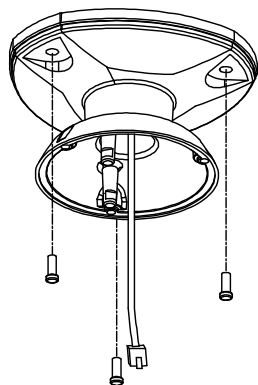

- ③ Screw the dome cover to the main body and remove the protection vinyl from the dome cover.

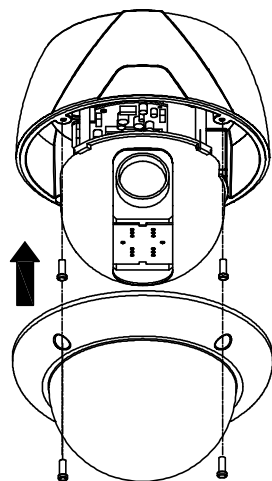

Important Notice

- Before starting the installation, make sure that the Camera ID and Protocol are set up properly.
- To adjust the installation height from the mounting surface, the pipe and coupler should be needed between the surface mount part of the ceiling mount bracket and the camera mount part of the ceiling mount bracket. Note that they are not supplied by the manufacturer.

Installation with Wall Mount Bracket

- ① Make a hole whose diameter is 30~40mm on the mounting surface to pass the wire(s) and cable(s) through the mounting surface. (In case of the wiring and cabling through the mounting surface only) Then prepare the wall mount bracket. Pull the wire(s) and cable(s) for the system as below. Attach the wall mount bracket to the mounting surface. (Hex Lag #14×50)
- ② Pull the wire(s) and cable(s) for the system as below. Wire the cable(s) to the ports. Insert the mounting hooks into the holes on the surface of the main body and turn the main body. Assemble the main both with the camera mount adaptor with the 3 screws. (Machine M5×15)

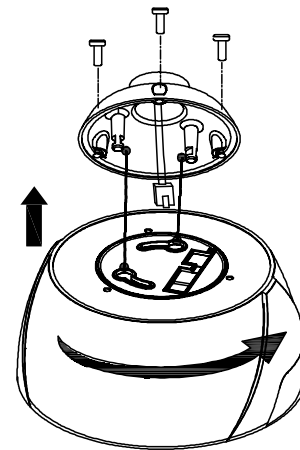
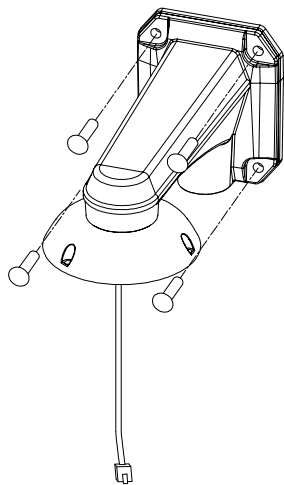

- ③ Screw the dome cover to the main body and remove the protection vinyl from the dome cover.

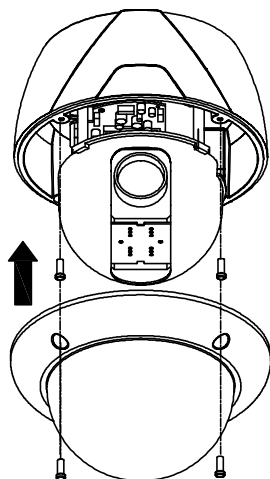

Important Notice

- Before starting the installation, make sure that the Camera ID and Protocol are set up properly.

Wiring and Cabling

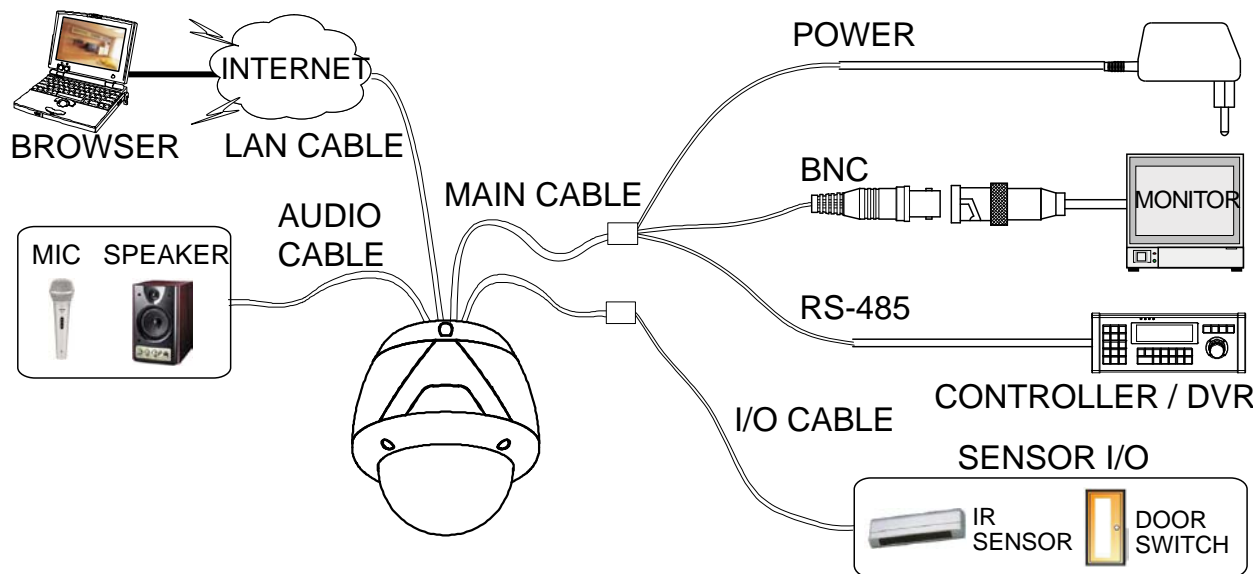

Port Description

● Main Cable

Port Pin Number (RJ45)	Connector / Wire Color	Signal
1	BNC Connector	Video +
2,4		Video -
5	Red	RS-485 +
3	Yellow	RS-485 -
7	Orange	Power +
6,8	White	Power -

● I/O Cable

Port Pin Number (RJ25)	Wire Color	Signal
1	Blue	IN COM +
2	Yellow	IN 1 -
3	Green	IN 2 -
4	Red	IN 3 -
5	Black	OUT A
6	White	OUT B

● Audio Cable

Port Pin Number	Connector / Wire Color	Signal
1	RCA (Yellow)	Audio IN
2		Audio GND
3	RCA (White)	Audio OUT

❑ Power Description

- Carefully check the voltage and current capacity of the rated power. The rated power is indicated in the back of main unit.

Model			Input Voltage Range	Current Consumption
DC12V Model	Analog Model	EAI-□□□□□-D□X	DC 11V ~ 18V	0.8 A
		EAO-□□□□□-D□X		2.5 A
	IP Addressable Model	EAI-□□□□□-D□N		1.3 A
		EAO-□□□□□-D□N		3.0 A
AC24V Model	Analog Model	EAO-□□□□□-A□X	AC 17V ~ 29V	1.5A
Dual Power Model	Analog Model	EAI-□□□□□-U□X	DC 11V ~ 18V or AC 17V ~ 29V	DC 12V, 0.8A / AC 24V, 0.4A

- For the DC input models, be careful with the polarity of DC power. The system should be permanently damaged by wrong DC input.
- In case that the length of the power wire is very long, there may be voltage drop and the system may not work properly. Make the length of the power wire as short as possible.

❑ RS-485 Communication

- For PTZ control, connect the cable(s) to your keyboard or DVR. To connect multiple cameras to a single controller, RS-485 communication should be connected in parallel as shown below. If you are connecting a single camera to a controller, terminate the camera. When connecting more than one camera to a single controller, terminate the last camera on the communication line. The last camera means the camera farthest in cable length from the controller. Note that the total length of the communication cable between a controller and the camera(s) on the same communication line must be less than 1.2Km.

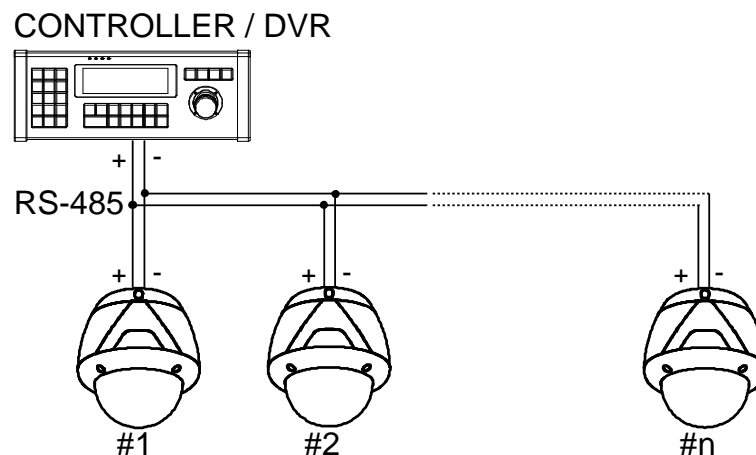

- ❑ Video
 - Use BNC coaxial cable only.

❑ Alarm Input

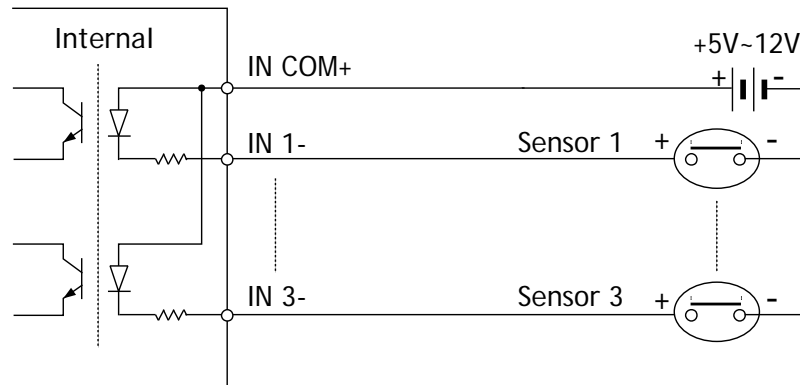

Before connecting sensors, check driving voltages and output signal types of the sensors. Since output signal types of the sensors are divided into Open Collector type and Voltage Output type in general, the wiring must be done properly after considering those types.

Signal	Description
IN COM+	The electric power source to drive input circuit. Connect the (+) wire of electric power source to drive the Sensors to this port as shown in the above circuit.
IN1 -, IN2 -, IN3 -	Connect the outputs of sensors to each port as shown in the above circuit.

If you want to use Alarm Input, the types of sensors must be selected in OSD menu. The sensor types are divided into Normal Open and Normal Close. If wrong sensor types are selected, alarms should be activated reversely to sensor inputs.

<input checked="" type="radio"/> Normal Open	Output Voltage is high state when sensor is activated
<input type="radio"/> Normal Close	Output Voltage is high state when sensor is not activated

❑ Relay Output

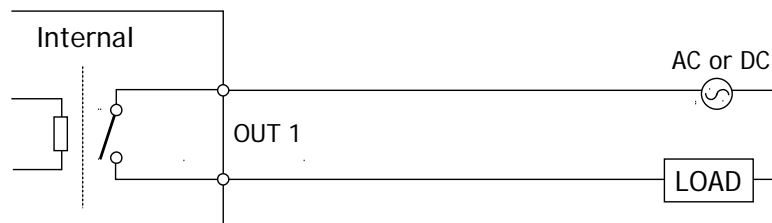

The maximum loads are as follows.

Power Type	DC Power	AC Power
Maximum Load	MAX. DC 24V, 1A	MAX. AC 125V, 0.5A

Check Points before Operation

- Before turning on the system, check if the wire(s) and cable(s) are connected properly.
- Check if the camera ID on the controller is properly selected. The camera ID must be identical to that of the target camera. The camera ID can be checked by reading the DIP switch of the camera or on OSD.
- If your controller supports multi-protocols, the protocol must be changed to match to that of the camera.
- Adjust the DIP switch after turning off the camera. If you changed the camera protocol by changing the DIP S/W, the change will be effective after you reboot the camera.
- Since the operation method can be different by controllers, refer to your controller manual if the camera can not be controlled properly. The operation of this manual is based on the standard Pelco® Controller.

Check Points for Preset and Pattern Function before Operation

- Check fully how to operate preset function and pattern function with your controller or DVR in advance to operate the camera functions when using a controller or a DVR.
- Refer to the following table when using standard Pelco® protocol controllers.

< Go Preset >	Input [Preset Number] and press [Preset] button shortly.
< Set Preset >	Input [Preset Number] and keep pressing [Preset] button for more than 2 seconds.
< Run Pattern >	Input [Pattern Number] and press [Pattern] button shortly.
< Set Pattern >	Input [Pattern Number] and keep pressing [Pattern] button for more than 2 seconds.

- If your controller or DVR has no pattern button or function, use the Hot Keys with preset numbers. For more information, refer to “**Reserved Presets(Hot Keys)**” in this manual.

OSD Menu

- Function With OSD menu, the system can be properly configured for each application.
- Entering into OSD Go Preset [95]

Reserved Presets (Hot Keys)

- Description Some Preset numbers are reserved to change some parameters without entering into OSD menu.
- Hot Keys
 - Go Preset [95] : Entering into OSD menu
 - Go Preset [131~134] : Running Pattern Function 1 ~ 4
 - Go Preset [141~148] : Running Swing Function 1 ~ 8
 - Go Preset [151~158] : Running Group Function 1 ~ 8
 - Go Preset [161] : Turning off Relay Output
 - Set Preset [161] : Turning on Relay Output
 - Go Preset [167] : Setting Zoom Proportional Function to ON
 - Set Preset [167] : Setting Zoom Proportional Function to OFF
 - Go Preset [170] : Setting Camera BLC/WDR Mode to OFF
 - Go Preset [171] : Setting Camera BLC/WDR Mode to ON
 - Go Preset [174] : Setting Camera Focus Mode to AUTO
 - Go Preset [175] : Setting Camera Focus Mode to Manual
 - Go Preset [176] : Setting Camera Focus Mode to SEMI-AUTO
 - Go Preset [177] : Setting Day & Night Mode to AUTO
 - Go Preset [178] : Setting Day & Night Mode to NIGHT
 - Go Preset [179] : Setting Day & Night Mode to DAY
 - Go Preset [190] : Setting OSD Display Mode to AUTO (Except Privacy Mask)
 - Go Preset [191] : Setting OSD Display Mode to OFF (Except Privacy Mask)
 - Go Preset [192] : Setting OSD Display Mode to ON (Except Privacy Mask)
 - Go Preset [193] : Setting all Privacy Mask Display to OFF
 - Go Preset [194] : Setting all Privacy Mask Display to ON

Preset

- **Function** MAX. 127 positions are programmable. The Preset number can be assigned from 1 to 128 except 95. Preset 95 is reserved for entering into OSD menu. Camera parameters such as White Balance, Auto Exposure and others can be set up independently and each preset can have its own parameter values independently from the other presets. When setting up presets with a controller, Label should be blank and "Camera Adjust" should be set to "GLOBAL" as the default. To change the parameters, enter into OSD menu.
- **Setting Presets** Set Preset [1~128]
- **Running Presets** Go Preset [1~128]
- **Deleting Presets** To delete Presets, enter into OSD menu.

Swing

- **Function** This function is that the camera moves repetitively between two preset positions at programmed speeds. When a swing function runs, the camera moves from the preset assigned as the 1st point to the preset assigned as the 2nd point in CW(Clockwise) direction. Then the camera moves from the preset assigned as the 2nd point to the preset assigned as the 1st point in CCW(Counterclockwise) direction.

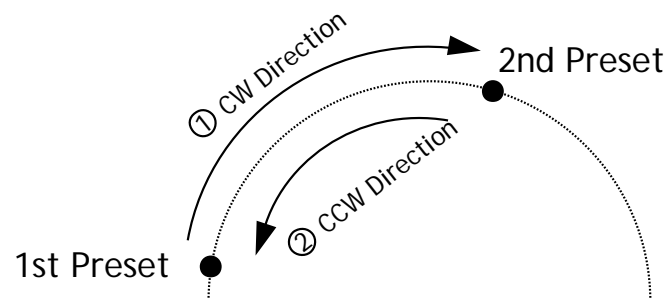

In case that the preset assigned as the 1st point and the preset assigned as the 2nd point are same, the camera turns on its axis by 360° in CW(Clockwise) direction and then it turns back on its axis by 360° in CCW(Counterclockwise) direction. The Swing speed is defined from 1°/sec to 180°/sec.

- **Setting Swings** To set Swing, enter into OSD menu.
- **Running Swings** Method 1) <Run Pattern> [Swing NO. + 10] ex) Run Swing 3 : <Run Pattern> [13]
Method 2) <Go Preset> [Swing NO. + 140] ex) Run Swing 3 : <Go Preset> [143]
- **Deleting Swings** To delete Swings, enter into OSD menu.

Pattern

- **Function** This function is that the camera memorizes the path (mostly curve path) by the joystick of the controller and revives the trajectory operated by joystick as closely as possible.
MAX. 4 Patterns are programmable and Maximum 1200 communication commands can be programmed in a pattern.

- **Setting Patterns** A Pattern can be created by the following methods.

Method 1) <Set Pattern> [Pattern NO.]

- The Pattern programming window appears on the monitor as below.

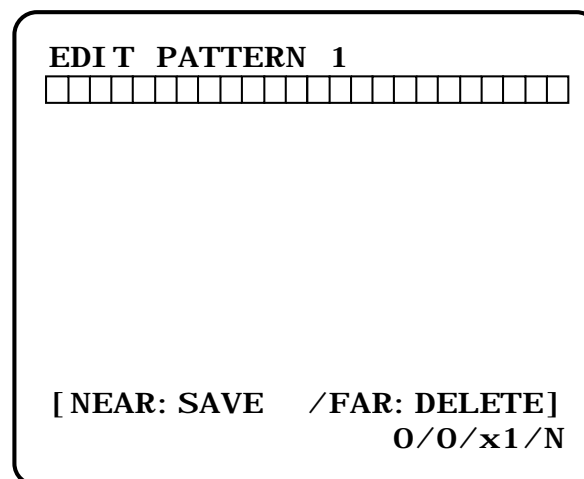

- The movement by Joystick and the preset movement can be memorized in a pattern.
- After a pattern is programmed, the remaining storage is displayed in progress bar on the screen.
- To save the recording, press **NEAR** key and to cancel, press **FAR** key.

Method 2) Programming in OSD Menu : See the section "How to use OSD Menu".

- **Running Patterns** Method 1) <Run Pattern> [Pattern NO.] ex) Run Pattern 2 : <Run Pattern> [2]
Method 2) <Go Preset> [Pattern NO. + 130] ex) Run Pattern 2 : <Go Preset> [132]
- **Deleting Patterns** To delete Patterns, enter into OSD menu.

Note) When the system memorizes Patterns, the commands are stored in the memories, not the positions of Pan/Tilt/Zoom. Hence there might be small differences between the original path and the revived path by path type of Patterns. Note that it is not a problem in position precision.

Group

- Function

This function is that the camera memorizes the combination of Presets, Pattern and/or Swings sequentially and runs Presets, Pattern and/or Swings repetitively. MAX. 8 sets of Group are programmable. Each group can have MAX. 20 actions which are the combination of Preset, Pattern and Swing. Preset speed can be set up and the repeat number of Pattern & Swing can be set up in Group setup. Dwell time between actions can be set up also.

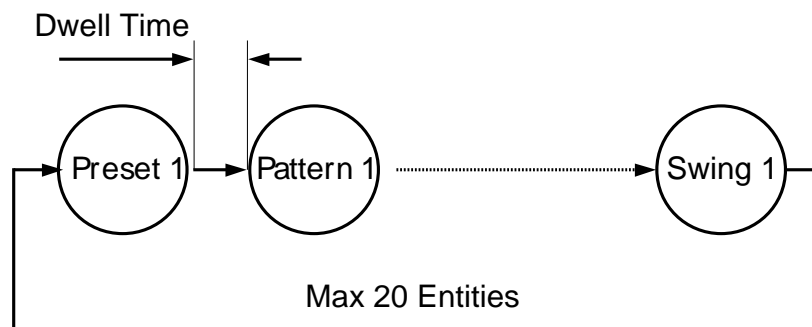

- Setting Groups

To set Groups, enter into OSD menu.

- Running Groups

Method 1) <Run Pattern> [Group NO. + 20] ex) Run Group 7 : <Run Pattern> [27]
 Method 2) <Go Preset> [Group NO. + 150] ex) Run Group 7 : <Go Preset> [157]

- Deleting Groups

To delete Groups, enter into OSD menu.

Other Functions

- Power Up Action

This setting defines a specific activity (Preset, Pattern, Swing and Group) to be performed in the event that the power to the camera is cycled. This function enables the user to resume, after turning on power, the last action being executed before turning off the power. Most of actions such as Preset, Pattern, Swing and Group are available for this function but Jog actions are not available to resume.

- Auto Flip

In case that tilt angle arrives at the top of tilt orbit(90°), zoom module camera turns on its axis by 180° at the top of tilt orbit and moves to opposite tilt direction (180°) to keep tracing targets.

- Parking Action

This feature allows the camera to begin a specified operation after a programmed time of inactivity. This function makes the camera automatically run a pre-defined action if there is no command from controller for a pre-defined time period. "Wait Time" means how long a camera should wait for from the previous-last (most recent) command before running the pre-defined action. It can be set to 1 second ~ 3 hours.

-
- Alarm Input
3 Alarm Inputs are available. When external sensors activate, the camera runs pre-defined actions such as Preset, Pattern, Swing and Group. After the pre-defined time period passed, "Post Alarm" activates, which is pre-defined. Note that only the latest alarm input is effective when multiple sensors are activated at the same time.
 - Privacy Zone Mask
Privacy Zone Mask allows the user to program 8 rectangulars that can not be viewed by the operator of the system. To protect others' privacy, MAX. 8 Privacy Masks can be created on the arbitrary position to hide objects such as windows, shops or private house. With the Spherical Coordinates system, powerful Privacy Zone Mask function is possible. A mask area will move with pan and tilt functions and automatically adjust in size as the lens zooms telephoto and wide.
 - GLOBAL/LOCAL Image Setup
WB(White Balance) and AE(Auto Exposure) can be set up independently for each preset. There are 2 modes, "Global" mode & "Local" mode. The Global mode is that WB and/or AE are/is set up totally and simultaneously for all presets. The Global parameter setup such as WB and AE can be done in "ZOOM CAMERA SETUP" menu. The Local mode is that WB and/or AE are/is set up independently or separately for each preset. The Local parameter setup for WB and AE can be done in each preset setup menu. Each Local parameter such as WB and AE activates correspondingly when the camera arrives at each preset position. During jog operation, Global WB/AE value should be applied. All Local WB/AE values do not change although Global WB/AE value changes. The Local mode has the prior to the Global mode.
 - Semi-Auto Focus
This mode automatically exchanges focus modes between Manual Focus mode and Auto Focus mode by operation. Manual Focus mode activates in preset operation and Auto Focus mode activates during jog operation. With Manual mode at presets, Focus data is memorized in each preset in advance and the camera calls focus data in correspondence with presets as soon as the camera arrives at presets. It should shorten time to get focuses. The focus mode automatically changes to Auto Focus mode when jog operation starts.

OSD Display

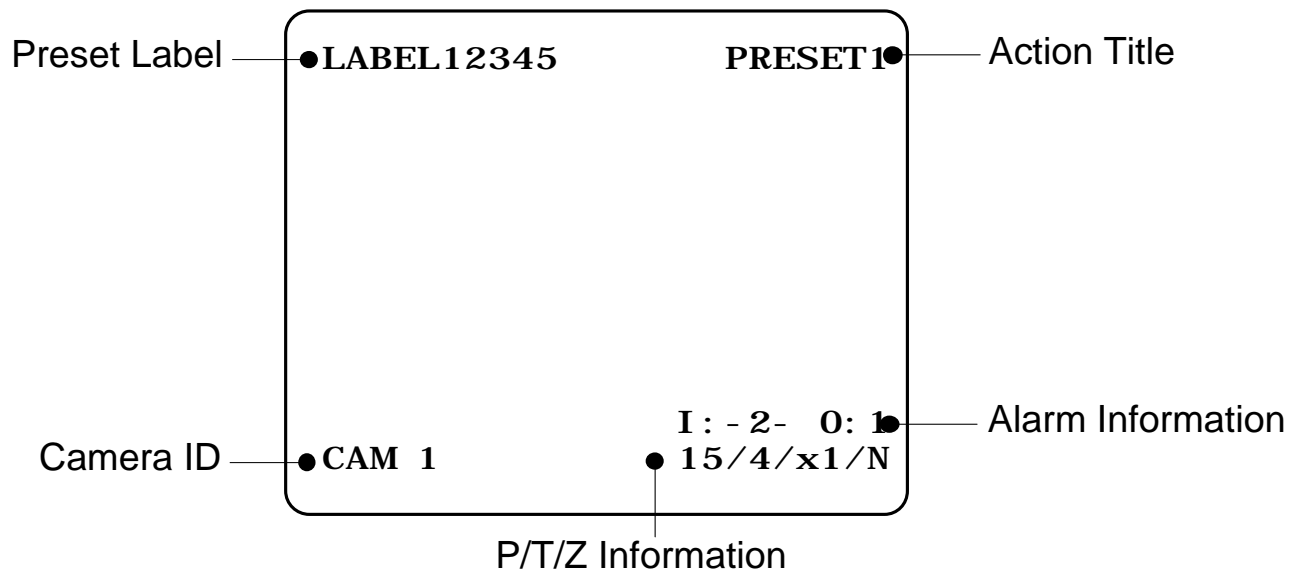

- **P/T/Z Information** Displays the amount of pan from zero degree vertical, the amount of tilt from zero degree horizontal and current compass direction. Also identifies the amount of the zoom magnification.
- **Camera ID** Displays the selected Camera ID (Address).
- **Action Title** Identifies Actions

"SET PRESET xxx"	When Preset xxx is memorized.
"PRESET xxx"	When the camera reaches Preset xxx.
"PATTERN x"	When Pattern x is in action.
"SWGx/PRESET xxx"	When Swing x is in action. Displays both of Swing number and Preset number.
"UNDEFINED"	When a undefined function is called to run
- **Preset Label** Displays preset labels when the camera arrives at presets.
- **Alarm Information** Displays activated alarms. This information shows current state of Alarm Inputs and Relay Outputs. If an Input point is **ON** state, it will show a number corresponding to each point. If an Input point is **OFF** state, '-' will be displayed.
 Example) The point 2 & 3 of inputs are **ON** and Output is **ON**, OSD will show as below.

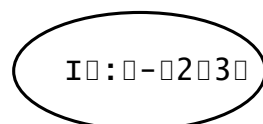

Quick Programming Guide

- The menu items with < > always have sub-menus.
- To go to submenus or make the cursor move to the right, press **NEAR** key.
- To go to the previous-upper level menus, press **FAR** key.
- To make a selection, press **NEAR** key
- To cancel a selection, press **FAR** key
- To move the cursor in the menu, use the joystick to the **Up/Down** direction or **Left/Right** direction.
- To change a value of an item, use **Up/Down** of the joystick in the controller.
- To save changes, press **NEAR** key.
- To cancel changes, press **FAR** key.

Main Menu

SPEED DOME CAMERA

```
-----
-><SYSTEM INFORMATION>
  <DISPLAY SETUP>
  <DOME CAMERA SETUP>

  <SYSTEM INITIALIZE>
```

```
—
EXIT
```

- **System Information** Displays the system information and configuration. The system setting can not be changed using the OSD menu and the information is for reference only.
- **Display Setup** Enables the user to program how labels are displayed on the monitor.
- **Dome Camera Setup** Enables the user to configure various functions of the camera.
- **System Initialize** Initializes all system configurations and all data to the factory default parameters.

Display Setup

DISPLAY SETUP

```

-----
->CAMERA ID          ON
PTZ INFORMATION     AUTO
ACTION TITLE        AUTO
PRESET LABEL         AUTO
ALARM I/O           AUTO
<SET NORTH DIRECTI ON>
<PRIVACY ZONE>

BACK
EXIT

```

Display setup allows you to program how labels are displayed on the monitor. In case of AUTO, the labels are displayed on the monitor when there are any changes in parameters.

- Camera ID [ON/OFF]
Displays the selected Camera ID (Address).
- PTZ Information [ON/OFF/AUTO]
Displays the amount of pan from zero degree vertical, the amount of tilt from zero degree horizontal and current compass direction. Also identifies the amount of the zoom magnification.
- Action Title [ON/OFF/AUTO]
Identifies Actions.
"SET PRESET xxx"
"PRESET xxx"
"PATTERN x"
"SWG/PRESET xxx"
"UNDEFINED"
- Preset Label [ON/OFF/AUTO]
Displays the preset labels when the camera arrives at presets.
- Alarm I/O [ON/OFF/AUTO]
Displays the activated alarms. This information shows the current state of Alarm Inputs and Relay Outputs. If an Input point is **ON** state, it will show a number corresponding to each point. If an Input point is **OFF** state, '-' will be displayed.
Example) The point 2 & 3 of inputs are **ON** and Output is **ON**, OSD will show as below.

I: - 23 0: 1

❑ Compass Direction Setup

SET NORTH DIRECTION

MOVE TO TARGET POSITION
[NEAR: SAVE /FAR: CANCEL

Move the camera to a target position and press **NEAR** button to save the direction as North. The direction is the reference direction to assign other compass directions.

Privacy Zone Mask Setup

PRIVACY ZONE

→MASK NO 1
 UNDEFINED

 DISPLAY OFF

 CLEAR MASK CANCEL

 <EDIT MASK>

BACK
EXIT

Privacy Zone Mask allows the user to program 8 rectangulars that can not be viewed by the operator of the system. To protect privacy, MAX. 8 Privacy Masks can be created on the arbitrary position to hide objects such as windows, shops or private house. With the Spherical Coordinates system, powerful Privacy Zone Mask function is possible. A mask area will move with pan and tilt functions and automatically adjust in size as the lens zooms telephoto and wide.

- Mask NO [1~8]
Selects a Mask number to program. If the selected mask has already data, the camera moves as it was programmed. Otherwise, "UNDEFINED" will be displayed under the Mask number.
- Display [ON/OFF]
Sets if the mask of the selected mask number shows or not on the screen.
- Clear Mask [CANCEL/OK]
Deletes the mask data of the selected mask number.

□ Privacy Zone Mask Area Setup

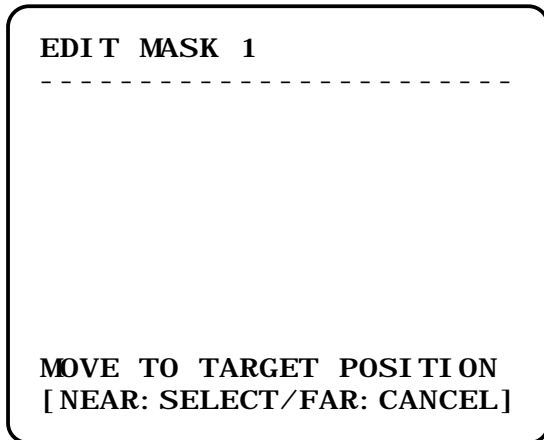

Move your camera to an area to mask. Then a mask and the menu to adjust the mask size will be displayed.

□ Privacy Zone Mask Size Setup

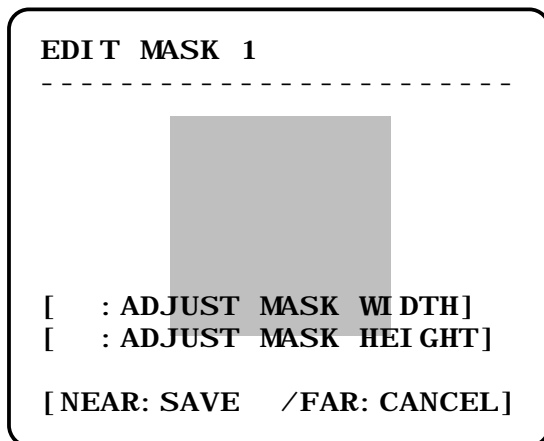

Adjusts the mask size. Use the joystick or the arrow buttons of your controller to adjust mask size.

- ◀ ▶ (Left/Right) Adjusts the mask width.
- ▲ ▼ (Up/Down) Adjusts the mask height.

Camera Setup

ZOOM CAMERA SETUP

```

-----
-> FOCUS MODE      SEMI AUTO
   DIGITAL ZOOM    ON
   IMAGE FLIP      OFF
   SHARPNESS       16
   STABILIZATION   OFF
   <WHITE BALANCE SETUP>
   <AUTO EXPOSURE SETUP>

BACK
EXIT
  
```

Sets the general functions of zoom camera module.

- Focus Mode [AUTO/MANUAL/SEMIAUTO]
Sets camera Focus mode.
 - SEMIAUTO Mode
This mode automatically exchanges focus modes between Manual Focus mode and Auto Focus mode by operation. Manual Focus mode activates in preset operation and Auto Focus mode activates during jog operation. With Manual mode at presets, Focus data is memorized in each preset in advance and the camera calls focus data in correspondence with presets as soon as camera arrives at presets. It should shorten time to get focuses. Focus mode automatically changes to Auto Focus mode when jog operation starts.
- Digital Zoom [ON/OFF]
Sets the digital zoom functions to ON/OFF. If this is set to OFF, the optical zoom function runs but the zoom function stops at the end of optical zoom magnification.
- Image Flip [ON/OFF]
Sets System Image Flip Function to ON/OFF. When this function is set to ON, flipped images always come out. When the camera is installed as Desktop type, set to ON to get proper images.
- Sharpness [0-32]
Sets image sharpness to enhance pictures.

- Stabilization [ON/OFF]
Compensates image vibrations by wind or others. The images with vibrations are compensated by Digital Zoom function and the image resolution with this function should be lower than normal image resolution when this function is turned on. Also this function may not work properly in the following cases.
 - Dark scene or Low contrast scene
 - High frequency vibration
 - During Pan/Tilt/Zoom/Focus moving
 - During Iris/Shutter/Gain moving

□ White Balance Setup

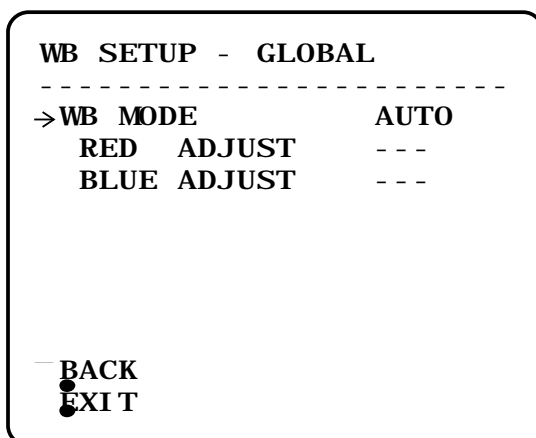

- WB Mode [AUTO/MANUAL]
Retains color balance over a color temperature range. In auto mode, this feature automatically processes the viewed image. In Manual mode, Red and Blue level can be set up manually.
- Red Adjust [0-255]
Adjusts the picture output in the red range.
- Blue Adjust [0-255]
Adjusts the picture output in the blue range.

□ Auto Exposure Setup

AE SETUP - GLOBAL	

→ BACKLIGHT	OFF
DAY/NIGHT	AUTO
BRIGHTNESS	50
IRIS	AUTO
SHUTTER	ESC
AGC	MIDDLE
SSNR	MIDDLE
SENS-UP	<AUTO>
BACK	
EXIT	

- Backlight [OFF/WDR/BLC/HLC] or [OFF/BLC/HLC]
Sets Backlight Compensation. If a bright backlight is present, the subjects in the picture may appear dark or as a silhouette. Backlight compensation enhances objects in the center of the picture. The camera uses the center of the picture to adjust the iris. If there is a bright light source outside of this area, it will wash out to white. The camera will adjust the iris so that the object in the sensitive area is properly exposed.
Some modles has WDR(Wide Dynamic Range) function, which are better function than BLC. HLC(High Light Compensation) function removes the high light in a limited environment such as parking garage.
- Day/Night [AUTO/DAY/NIGHT]
Sets Day&Night mode.
- Brightness [0~100]
Adjusts the brightness of the images. Iris, The Shutter Speed and Gain are adjusted automatically in correspondence with each numeric value.
- IRIS [AUTO/MANUAL(F1.6~F28)]
Sets Iris to operate automatically or at a user-defined level. If Iris is set to Auto, Iris has higher priority in adjusting AE and Shutter Speed is fixed. Auto iris is the lens function that automatically opens closes the iris in response to changing light conditions.
If Iris is set to Manual, Iris is fixed and Iris has lower priority in adjusting AE, in comparison with others.

-
- Shutter Speed [ESC/A.Flicker/Manual(×256~1/120000 sec)]
Sets Shutter Speed. Shutter Speed is the duration of the electronic shutter. If Iris is set to Manual and Shutter Speed is set to ESC, Shutter Speed has higher priority. If Shutter Speed is set to A.Flicker, to remove Flicker, Shutter Speed should be set to 1/100 sec. for NTSC and 1/120 for PAL.
 - AGC [OFF/LOW/MIDDLE/HIGH/MANUAL(5~41dB)]
Sets AGC. This setting enhances image brightness automatically in case that luminance level of image signal is too low.
 - SSNR [OFF/LOW/MIDDLE/HIGH]
Sets SSNR. This setting enhances the images by deducting noises when the gain level of the images is too high.
 - SENS-UP [AUTO(2~256)/OFF]
Sets SENS-UP. This setting activates Slow Shutter function when luminance of image (signal) is too dark.
It is possible to set up the maximum number of frames piled up one on another by Slow Shutter function.

❑ WDR (Wide Dynamic Range) Setup

WDR

->LIMIT MIDDLE
 LEVEL 50

BACK
EXIT

● Limit

[LOW/MIDDLE/HIGH]

● Level

[0~100]

❑ HLC (High Light Compensation) Setup

HLC

->LIMIT LOW
 COLOR 5

BACK
EXIT

● Limit

[AUTO/MANUAL]

When there are too bright lights, this function blocks light sources on images to have better images. For example, when there is a car coming to a camera at night, this function blocks car headlights to recognize its number plate.

● Color

[0~10]

Assigns colors of masks to block light sources

Motion Setup

MOTION SETUP

```

-----
->MOTION LOCK      OFF
PWR UP ACTION     ON
AUTO FLIP         ON
JOG MAX SPEED     120/SEC
JOG DIRECTION     INVERSE
FRZ IN PRESET     OFF
<PARKING ACTION SETUP>
<ALARM INPUT SETUP>
BACK
EXIT

```

Sets the general functions of Pan/Tilt motions.

- Motion [ON/OFF]
Lock If Motion Lock is set to ON, it is impossible to set up and delete Preset, Swing, Pattern and Group. It is possible only to run those functions. To set up and delete those functions, enter into OSD menu.
- Power Up [ON/OFF]
Action Refer to "Other Functions" section.
- Auto Flip [ON/OFF]
Refer to "Other Functions" section.
- Jog Max [1°/sec ~360°/sec]
Speed Sets the maximum jog speed. Jog speed is inversely proportional to the zoom magnifications. As the zoom magnification goes up, the pan/tilt speed goes down.
- Jog [INVERSE/NORMAL]
Direction Sets the Jog Direction. If this is set to 'Inverse', the view direction in the screen is same as the direction of joystick. If this is set to 'Normal', the view direction in the screen is the reverse direction of joystick.
- Freeze [ON/OFF]
in Preset Sets Frame Freeze Function. This feature freezes the scene on the monitor when going to a preset. At the start point of a preset movement, a camera starts freezing the image of the start point. Camera keeps displaying the image of the start point during preset movement and does not display the images which camera gets during preset movement. As soon as camera stops at preset end point, camera starts displaying live images which it gets at the end preset point. This feature also reduces bandwidth when working with digital systems or digital network systems.
This function availability should be different by models.

□ Parking Action Setup

PARKING ACTION SETUP	

→ PARK ENABLE	OFF
WAIT TIME	00: 10: 00
PARK ACTION	HOME
BACK	
EXIT	

This feature allows the camera to begin a specified action after a programmed time of inactivity.

- Park Enable [ON/OFF]
If Park Enable is set to ON, the camera runs an assigned function automatically if there is no PTZ command during the programmed "Wait Time".
- Wait Time [1~59 sec. / 1~180 min.]
Wait Time can be programmed from 1 second to 180 minutes.
- Park Action [HOME/PRESET/PATTERN/SWING/GROUP/PREV ACTION]
This feature defines the activity when the camera parks. If Park Action is set to "HOME", the camera moves to the home position which is memorized when the system boots. If Park Action is set to "PREV. ACTION", the camera runs the previous action which it ran most recently.

□ Alarm Input Setup

ALARM INPUT SETUP	

→ALARM NO.	1
TYPE	N. OPEN
ACTION	NOT USED
HOLD TIME	ENDLESS
POST ACTION	HOME
BACK	
EXIT	

Defines Alarm Function. When an alarm is received, an input signal to the camera triggers the user-defined action programmed for the alarm.

- Alarm No [1~3]
Selects a sensor number to set up.
- Type [Normal OPEN/Normal CLOSE]
Selects sensor operation type.
- Action [NOT USED/PRESET/PATTERN/SWING/GROUP]
Selects an action to run when a sensor signal is input.
- Hold Time [ENDLESS / 1~59 SEC. / 1~180 MIN.]
Sets the time period for the action which is run by external sensor activation. After the time period passes, the action pre-defined in "Post Action" runs sequentially in succession to the action by external sensor activation. If this option is set to "ENDLESS", "Post Action" does not activate.
- Post Action [HOME/PRESET/PATTERN/SWING/GROUP/PREV ACTION]
Selects the action that a camera will run after the time period in "HOLD TIME" passes. If Post Action is set to "PREV. ACTION", the camera runs the previous action which it ran most recently.

Preset Setup

```

PRESET SETUP
-----
->PRESET NO.      1

CLR PRESET       CANCEL
<EDIT SCENE>
<EDIT LABEL>    LABEL123
RELAY OUT        OFF
CAM ADJUST       GLOBAL

BACK
EXIT

```

- Preset Number [1~128]
Selects a preset number to set up. If a selected preset is already defined, the camera moves to the pre-defined position and preset parameters such as Label and CAM Adjust show on the monitor. If a selected preset is not defined, "UNDEFINED" shows on the monitor.
- Clear Preset [CANCEL/OK]
Deletes the data of the selected Preset.
- Edit Preset Scene
Re-defines the scene position of the selected Preset.
- Edit Preset Label
Edits the label of the selected Preset to show on the monitor when the preset runs. MAX. 10 alphanumeric characteristics are allowed.
- Relay Out
Defines the relay output.
- CAM Adjust [GLOBAL/LOCAL]
WB(White Balance) and AE(Auto Exposure) can be set up independently for each preset. There are 2 modes, "Global" mode & "Local" mode. The Global mode is that WB and/or AE are/is set up totally and simultaneously for all presets. The Global parameter setup such as WB and AE can be done in "ZOOM CAMERA SETUP" menu. The Local mode is that WB and/or AE are/is set up independently or separately for each preset. The Local parameter setup for WB and AE can be done in each preset setup menu. Each Local parameter such as WB and AE activates correspondingly when the camera arrives at each preset position. During jog operation, Global WB/AE value should be applied. All Local WB/AE values do not change although Global WB/AE value changes. The Local mode has the prior to the Global mode.

❑ Preset Scene Setup

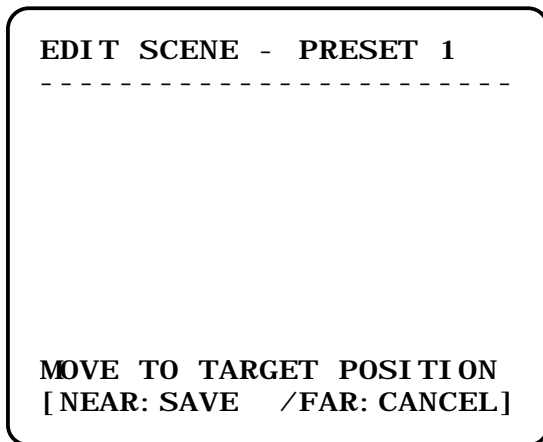

- ① Use the Joystick to move the camera to a desired position.
- ② Save the preset position by pressing **NEAR** key.
- ③ Press **FAR** key to cancel targeting the preset position.

❑ Preset Label Setup

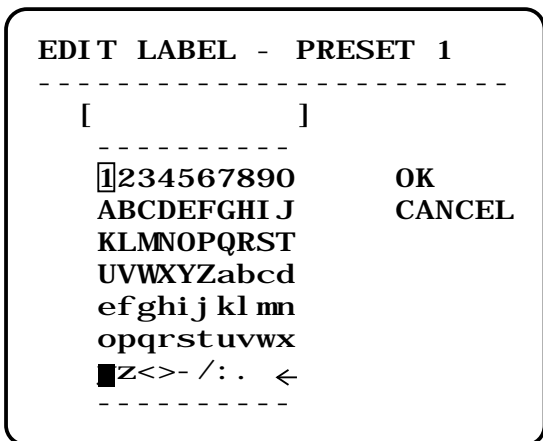

Edit the label of the selected preset to show on the monitor when camera arrives at the preset. In the Edit Label menu, the dark rectangular is the cursor. As soon as finishing selecting an alphabet or a number, the cursor moves to the next digit.



- ① With **Left/Right/Up/Down** of the joystick, move to a desired Alphabet or a desired number in the Alphanumeric set. To select a desired Alphabet or a desired number, press the **NEAR** key.

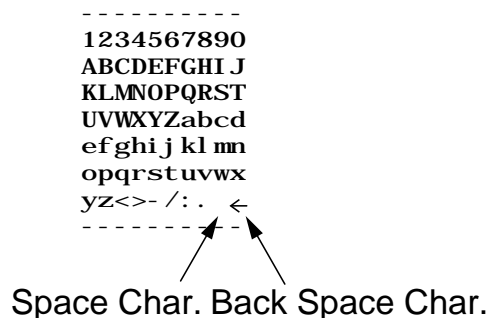

If you want to use a blank, select the double quotation mark (" "). If you want to delete an Alphabet or a number, use the back space character (" ←").

- ② If you complete the Label editing, move the cursor to "OK" and press the **NEAR** key to save the completed label. To abort the current change, move the cursor to "Cancel" and press the **NEAR** key.

Swing Setup

SWING SETUP	

-> SWING NO.	1
1ST POS.	NOT USED
2ND POS.	NOT USED
SWING SPEED	30/SEC
CLEAR SWING	CANCEL
RUN SWING	
BACK	
EXIT	

- **Swing Number** [1~8]
Selects a Swing number to edit. If the selected Swing is not defined, "NOT USED" is displayed in the 1st Position and the 2nd Position.
- **1st Position** [PRESET 1~128]
2nd Position Sets the 2 positions for a Swing function. If the selected preset is not defined, "UNDEFINED" is displayed as shown below.

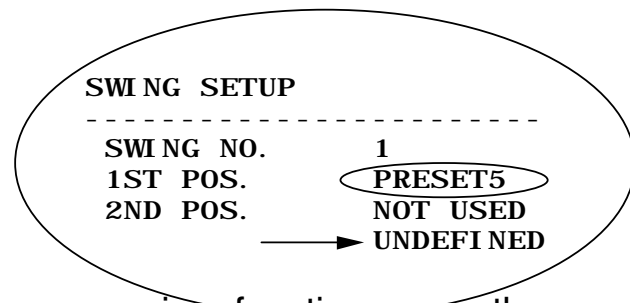

When a swing function runs, the camera moves from the preset assigned as the 1st point to the preset assigned as the 2nd point in CW(Clockwise) direction. Then the camera moves from the preset assigned as the 2nd point to the preset assigned as the 1st point in CCW (Counterclockwise) direction. In case that the preset assigned as the 1st point and the preset assigned as the 2nd point are same or only 1 Preset position is assigned, the camera turns on its axis by 360° in CW direction and then it turns on its axis by 360° in CCW direction.

- **Swing Speed** [1°/sec. ~180°/sec.]
Defines Swing speed between the 2 Preset positions from 1°/sec to 180°/sec
- **Clear Swing** [CANCEL/OK]
Deletes the data of the selected Swing.
- **Run Swing** Runs Swing for the test purposes to check if it works properly.

Pattern Setup

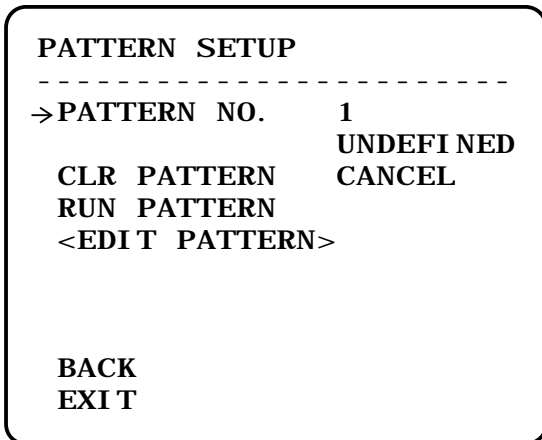

- Pattern Number [1~4]
Selects a Pattern number to edit. If the selected pattern number is not defined, "UNDEFINED" will be displayed under the selected pattern number.
- Clear Pattern [CANCEL/OK]
Deletes the data of the selected pattern.
- Run Pattern
Runs the Pattern for the test purposes to check if it works properly.
- Edit Pattern Edits the selected pattern.

□ Pattern Edit

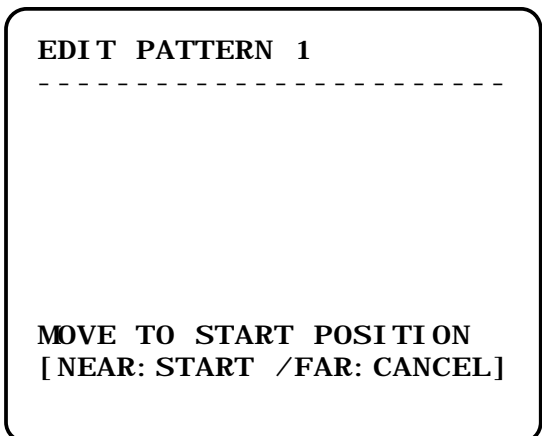

① With the Joystick of your controller, move the camera to the start position with an appropriate zoom magnification. To start the pattern recording, press **NEAR** key. To exit, press **FAR** key.

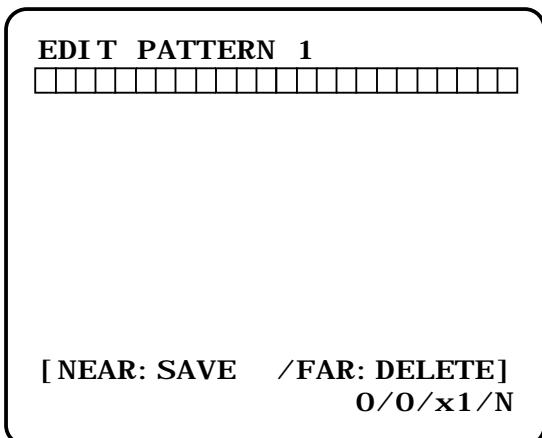

② Move camera with joystick of controller or run preset function to memorize the path (mostly curve path) in the selected pattern. The movement by Joystick and preset movement will be memorized in a pattern. After a pattern is programmed, the remaining storage is displayed in progress bar on the screen.

③ To save the data and exit, press **NEAR** key. To cancel saving the data and delete the data, press **FAR** key.

Group Setup

```

GROUP SETUP
-----
->GROUP NO.      1
                UNDEFINED
CLEAR GROUP     CANCEL
RUN GROUP
<EDIT GROUP>

BACK
EXIT
    
```

- Group Number [1~8]
Selects a Group number to edit.
If the selected Group number is not defined, "UNDEFINED" will be displayed under the selected Group number.
- Clear Group [CANCEL/OK]
Deletes the data of the selected Group.
- Run Group
Runs the Group for the test purposes to check if it works properly.
- Edit Group
Edit the selected Group.

□ Group Edit

```

EDIT GROUP 1
-----
->NO ACTION ### DWELL OPT
-----
 1 NONE
 2 NONE
 3 NONE
 4 NONE
 5 NONE
-----
SAVE
CANCEL [NEAR: EDIT]
    
```

- ① Press **Near** key when the cursor is at "NO" to start editing the selected Group.

```

EDIT GROUP 1
-----
NO ACTION ### DWELL OPT
-----
-> 1 NONE
 2 NONE
 3 NONE
 4 NONE
 5 NONE
-----
SAVE [NEAR: EDIT ACT]
CANCEL [FAR : EDIT END]
    
```

- ② Note that MAX. 20 actions are allowed in a Group. Move the cursor up/down to select an Action. Press **Near** key to edit.

```

EDIT GROUP 1
-----
NO ACTION ### DWELL OPT
-----
1 [NONE]
2 NONE
3 NONE
4 NONE
5 NONE
-----
SAVE [ : MOVE CURSOR]
CANCEL [ : CHANGE VAL. ]
    
```

③ Define Action, Dwell time and Option. Note that the dark rectangular is the cursor. Move the cursor **Left/Right** to select an item and move cursor **Up/Down** to change each parameter.

- Action ### [NONE/PRESET/SWING/PATTERN]
- DWELL [0 SEC. ~ 4 MIN.]
Sets the Dwell Time between functions.
- OPT Option. It is a preset speed when a preset is selected in the Action. It is the number of repeat when a Pattern or a Swing is selected in the Action.

```

EDIT GROUP 1
-----
NO ACTION ### DWELL OPT
-----
1 PRESET [1] 00: 03 360
2 NONE
3 NONE
4 NONE
5 NONE
-----
SAVE [ : MOVE CURSOR]
CANCEL [ : CHANGE VAL. ]
    
```

④ Edit the items such as Action, ###, Dwell and OPT by moving the cursor.

```

EDIT GROUP 1
-----
NO ACTION ### DWELL OPT
-----
-> 1 PRESET 1 00: 03 360
2 NONE
3 NONE
4 NONE
5 NONE
-----
SAVE [ NEAR: EDIT ACT]
CANCEL [ FAR : EDIT END]
    
```

⑤ After finishing editing a Action, press **Near** key to go to the previous-upper level menu (Step ②). Move the cursor **Up/Down** to select an Action number and repeat Step ② ~ Step ④ to keep editing the selected Group.

EDIT GROUP 1

NO ACTION ### DWELL OPT

1 PRESET 1 00:03 360
2 NONE
3 NONE
4 NONE
5 NONE

->SAVE
CANCEL

- ⑥ After finishing setting up, press **FAR** key to exit. Then the cursor will move to "SAVE". Press **Near** key to save the data.

System Initialization

SYSTEM INITIALIZE

```

-> CLEAR ALL DATA      NO
   CLR DISPLAY SET     NO
   CLR CAMERA SET      NO
   CLR MOTION SET      NO
   CLR EDIT DATA      NO
   REBOOT CAMERA       NO
   REBOOT SYSTEM       NO
  
```

```

BACK
EXIT
  
```

- Clear All Data Deletes all configuration data and the system is set to the factory default.
- Clear Display Set Initializes all the configuration data for Display.
- Clear Camera Set Initializes all the configuration data for Camera.
- Clear Motion Set Initializes all the configuration data for Motion.
- Clear Edit Data Deletes all the configuration data for Preset, Swing, Pattern and Group.
- Reboot Camera Reboots the zoom camera module.
- Reboot System Reboots the system.

□ Factory Default

● Display Parameters		● Camera Parameters	
Camera ID	ON	Focus Mode	SemiAuto
PTZ Information	AUTO	Digital Zoom	ON
Action Title	AUTO	Image Flip	OFF
Preset Label	AUTO	Sharpness	16
Alarm I/O	AUTO	Stabilization	OFF
North Direction	Pan 0°	White Balance	AUTO
Privacy Zone	Undefined	Backlight	OFF
		Day&Night	AUTO
		Brightness	50
		Iris	AUTO
		Shutter	ESC
		AGC	MIDDLE
		SSNR	MIDDLE
		SENS-UP	AUTO
● Motion Parameters		● User-Defined Data	
Motion Lock	OFF	Preset 1~128	Undefined
Power Up Action	ON	Swing 1~8	Undefined
Auto Flip	ON	Pattern 1~4	Undefined
Jog Max Speed	120°/sec	Group 1~8	Undefined
Jog Direction	INVERSE		
Freeze In Preset	OFF		
Park Action	OFF		
Alarm Action	OFF		

CAMERA PART (33T Model)		
Video Signal Format	NTSC	PAL
Image Sensor	1/4" Super HAD color CCD	
Total Pixels	811(H)×508(V) 410K	795(H)×596(V) 470K
Effective Pixels	768(H)×494(V) 380K	752(H)×582(V) 440K
Horizontal Resolution	550 TV Lines(Color), 680 TV Lines(B/W)	
Video Signal-to-Noise	50 dB (AGC Off)	
Zoom	×33 Optical Zoom, ×12 Digital Zoom	
Forcal Length	F1.6~3.6, f=3.5~115.5mm	
Angle of View	H : 55.5°(Wide)~1.77°(Tele) / V : 42.5°(Wide)~1.33°(Tele)	
Zoom Speed	2.2 sec (Wide to Tele)	
Minimum Illuminance	0.4 Lux (Color) / 0.02 Lux (B/W), 50 IRE / F1.6	
Day & Night	Auto / Day / Night(ICR)	
Focus	Auto / Manual / SemiAuto	
Iris	Auto / Manual	
Shutter Speed	×256 ~ 1/120000 sec	
AGC	Low / Middle / High / Manual / Off	
White Balance	Auto / Manual(Red, Blue Gain Adjustable. 1800°K~10500°K)	
BLC	BLC / HLC / Off	
Flickerless	Selectable	
SSNR	Low / Middle / High / Off	
Privacy Zone	8 Masks, Spherical Coordinate	
Stabilization	ON / OFF	

MECHANISM PART		
Movement Range	Pan	360°(Endless)
	Tilt	90°
Speed	Preset	360°/sec.
	Jog	0.05 ~ 360°/sec. (Proportional to Zoom)
	Swing	1~ 180°/sec.
Preset	127 Presets (Label, Independent Camera Parameter Setting)	
Pattern	4 Patterns [1200 Commands(Approx. 5 Minute) / Pattern]	
Swing	8 Swings	
Group	8 Groups (MAX. 20 Actions with The Combination of Preset, Pattern and Swing)	
Other Pan/Tilt Functions	Auto Flip, Auto Parking, Power Up Action and etc.	
Communication	RS-485	
Protocol	Pelco-D, Pelco-P Selectable	
OSD	English, Menu / PTZ information etc	
Sensor Input	3 Inputs, Photo-Coupler Type, DC 5V~12V	
Alarm Outputs	1 Output, Relay Output, MAX. Load DC24V 1A / AC125V 0.5A	
Fan	Always ON	
Heater	Operation Start from Internal Temperature 10°C	
Operation Temperature	0°C ~ 40°C (EAI Model) -30°C ~ 50°C (EAO Model)	

RATED POWER			
DC12V Model	Analog Model	EAI-□□□□□-D□X	DC 12V / 0.8 A
		EAO-□□□□□-D□X	DC 12V / 2.5 A
	IP Model	EAI-□□□□□-D□N	DC 12V / 1.3 A
		EAO-□□□□□-D□N	DC 12V / 3.0 A
AC24V Model	Analog Model	EAO-□□□□□-A□X	AC 24V / 1.5 A
Dual Power Model	Analog Model	EAI-□□□□□-U□X	Dual Power Input DC 12V / 0.8 A or AC 24V / 0.4 A

MECHANICAL			
		Ceiling Mount	Wall Mount
Material	Dome	Polycarbonate	
	Internal	Polycarbonate, ABS	
	External	Aluminium	
Dome Size		Ø150mm / Ø 5.9"	
Dimension		Ø192×265.3 mm	296×276.6 mm
Weight		Approx 3.2 Kg	Approx 3.8Kg

[Note]

- 1) Specification and features are subject to change without prior notice.**
- 2) Specification and features are different by models.**
- 3) Check the voltage and current capacity of rated power carefully.**

Dimension

● Main Body

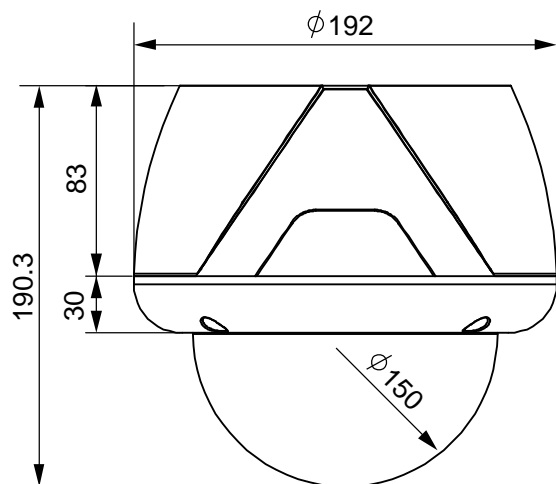

● Ceiling Mount Type

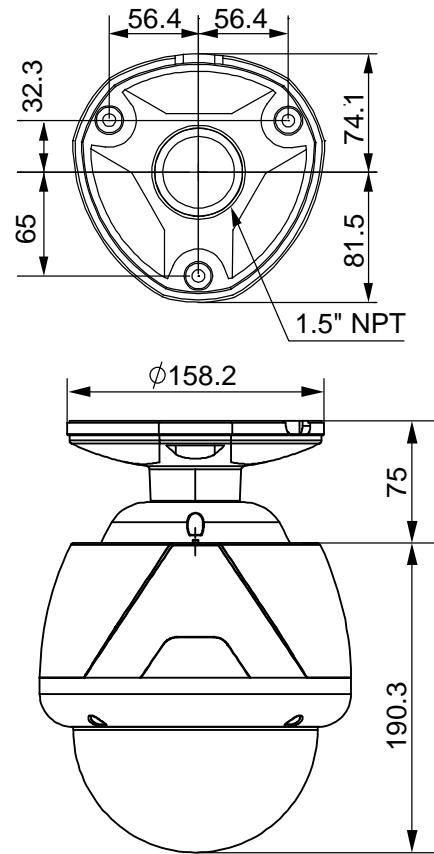

● Wall Mount Type

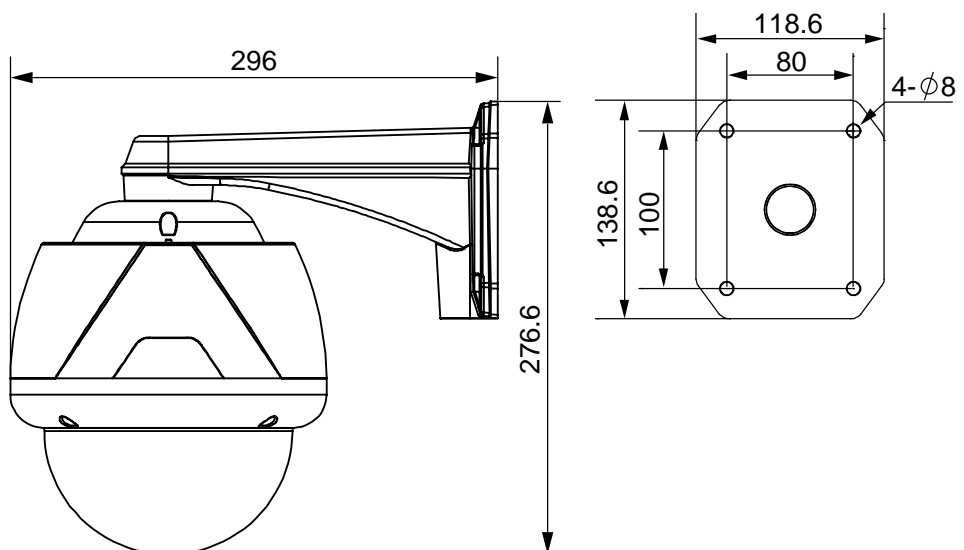

[Unit : mm]